



COMPACT LC urinal control. By SCHELL.
Integrated sensor for perfect hygiene.

SCHELL. The Company. For public and commercial sanitary rooms.



Factory 1 - Production with administration building and training centre



Factory 2 - Production with logistics centre



**Choose the Original
Choose Success!**

SCHELL supports original technology and opposes the infringement of intellectual property rights.

SCHELL - reliable partner for the sanitary industry - can look back over 75 years of experience in the design and manufacture of practical sanitary and heating fittings. High-quality basic materials and automated manufacturing processes are the foundation for quality fittings "Made by SCHELL in Germany".

Furthermore, SCHELL continuously tackles new topics and turns them into innovative products which genuinely benefit both the user and the trade. This includes the economical use of resources such as drinking water, as well as adherence to all rules and regulations that relate to safeguarding drinking water hygiene, uncompromising quality, easy installation and a comprehensive service tailored to the requirements of this professional trade.

SCHELL fittings meet many national and international licensing requirements and have been awarded with several design prizes. These facts, along with continuously tested safety and reliability, is another reason why numerous customers repeatedly choose SCHELL.

The trade- and user-focused strategy of SCHELL has been cultivated over decades and adapted to market requirements. Customers recognise the value in this. They in turn have made the company successful. Today, SCHELL has more than 450 employees working at two ultra-modern plants in Olpe with a wide product range and is one of the leading manufacturers of fittings in Europe.

The versatile sensor control for all urinals. Hygienic, water-saving and vandal-proof.

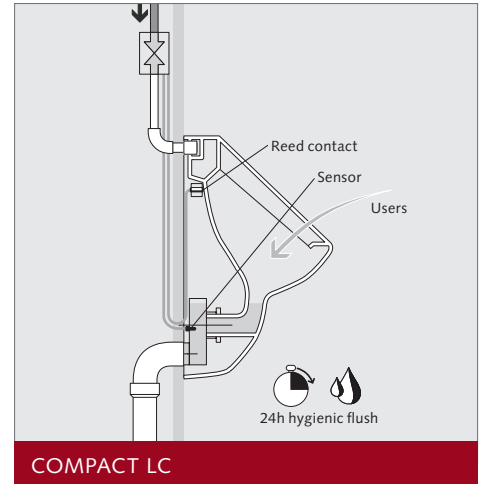

COMPACT LC - Liquid Control. SCHELL completes the range of contact-free urinal controls with the new LC sensor technology. The COMPACT LC control can be used universally for all urinal bowls (including stainless steel bowls) together with the COMPACT II urinal roughing-in set. The fully enclosed LC sensor is corrosion-proof and reliably detects liquid flows even when there are major urine deposits or scaling. The control unit is programmed by a REED switch which is activated by a magnetic reed contact. This means that three flush programs as well as one service and one diagnosis program can be easily set.

Easy installation of this discrete technology.

All necessary components for the urinal are included in the set.

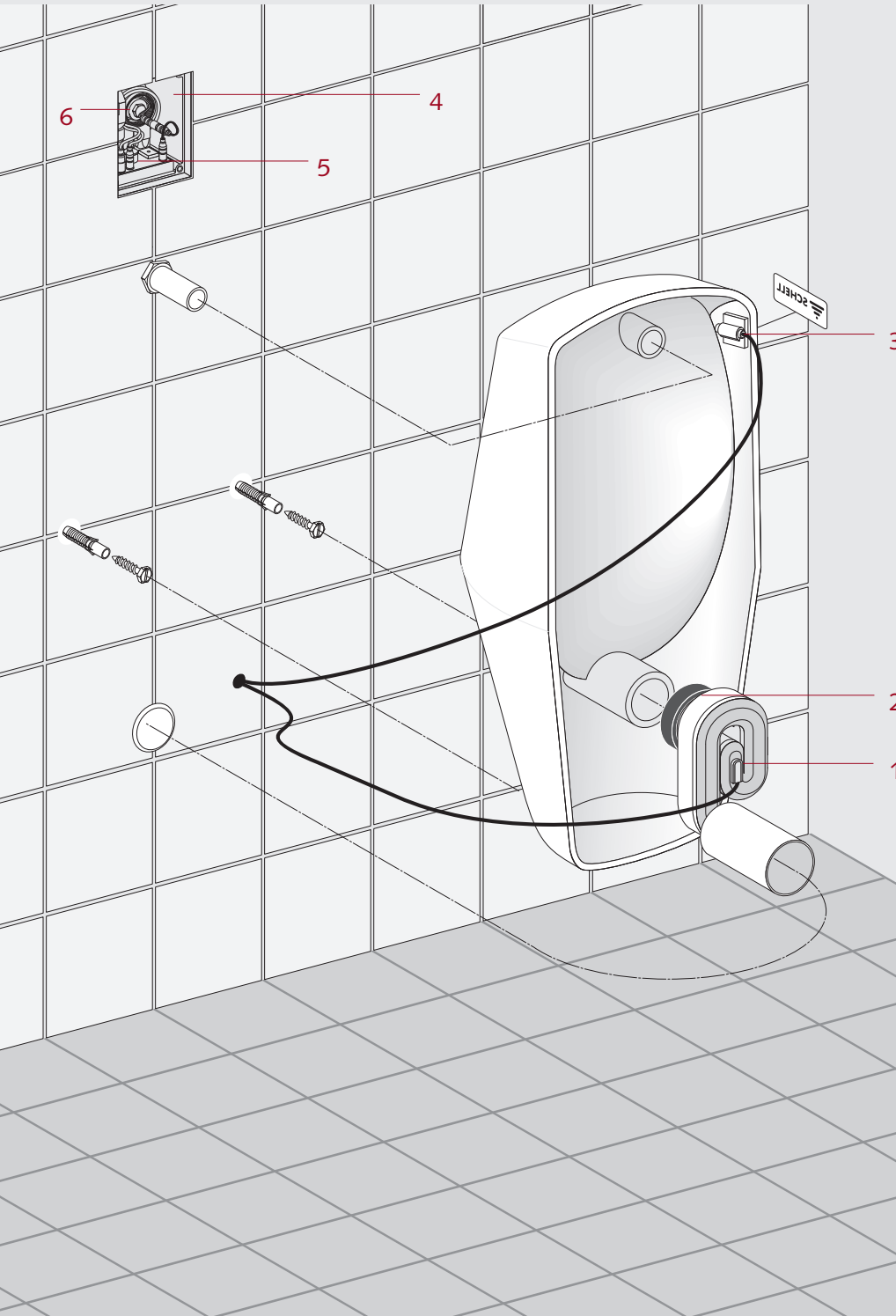

Installation.

The tried and tested COMPACT and COMPACT II roughing-in sets and the urinal mounting modules can be used for the COMPACT LC urinal control. The electronic module and power supply components (mains adapter or battery compartment) can be easily integrated into the roughing-in set.

The LC sensor is fitted into the siphon supplied, without the need for tools. The small REED switch is installed directly on the back of the ceramic unit when installing the bowl. The roughing-in set can be flexibly installed behind the ceramic unit or up to 2.5 m away from the sensor.

- 1 LC sensor
- 2 Siphon
- 3 REED switch for programming
- 4 COMPACT or COMPACT II urinal roughing-in set
- 5 Integrated electronics
- 6 Integrated mains adapter or battery compartment

PROGRAMMING	
Flush programs	
1st flush program	1 litre flush program*
2nd flush program	2 litre flush (factory setting)*
3rd flush program	Hybrid flush for urinals with a sealing liquid
<i>*with stagnation flush (24 h after the last use); stadium program automatically switches on when user frequency is high (reduced flush volume)</i>	
Service programs	
Cleaning stop 3 minutes	
Cleaning flush 10 s	
Interval flush for intensive cleaning (5 flushes for every 2 minutes of exposure)	
Diagnostic program	
System inspection: Solenoid valve, sensor, battery level	
Additional functions	
Overflow protection: No flush if bowl is blocked	
Drain tap monitoring fills when the liquid level in the siphon is low	

TECHNICAL SPECIFICATIONS	
Flow pressure	0.5 - 5 bar
Flow	0.3 l / s
Noise class	I
Mains or battery operated.	

COMPACT LC	
Battery operated 6V roughing-in set	Item No. 01 196 00 99
Mains operated 230 V/50 Hz roughing-in set	Item No. 01 197 00 99
Compact II concealed urinal flush valve	Item No. 01 193 00 99
COMPACT II HF/LC urinal mounting module	Item No. 03 283 00 99
COMPACT II urinal mounting module	Item No. 03 282 00 99
EDITION HF/LC urinal front panel	Item No. 23 080 28 99

Advantages at a glance:

- Installation independent of the ceramic unit
- For mains and battery operation
- Stadium program
- 3 flush programs
- Cleaning flush and cleaning stop
- Hygiene flush 24 h after the last flush
- Drain tap monitoring
- Overflow protection if siphon is blocked
- Diagnostic program for checking the system
- LC siphon included in the scope of delivery

Ranges of use:

- Restaurants
- Hotels
- Sports facilities
- Airports
- Commercial Buildings
- Industrial and commercial areas
- Hospitals and Medical Facilities
- Service stations and camping sites

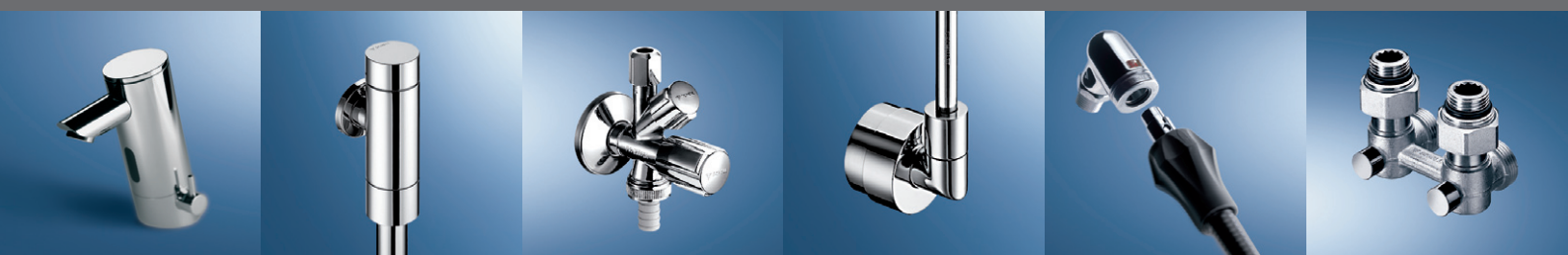

SCHELL GmbH & Co. KG
Armaturentechnologie
Raiffeisenstraße 31
D-57462 Olpe
Tel. ++49 27 61-8 92-0
Fax ++49 27 61-8 92-1 99
info@schell.eu
www.schell.eu